

# Environmental Product Declaration

according to ISO 21930



## SB1156F

Water Pressure Regulator for Hydronic Systems

Product Family: Hydronics

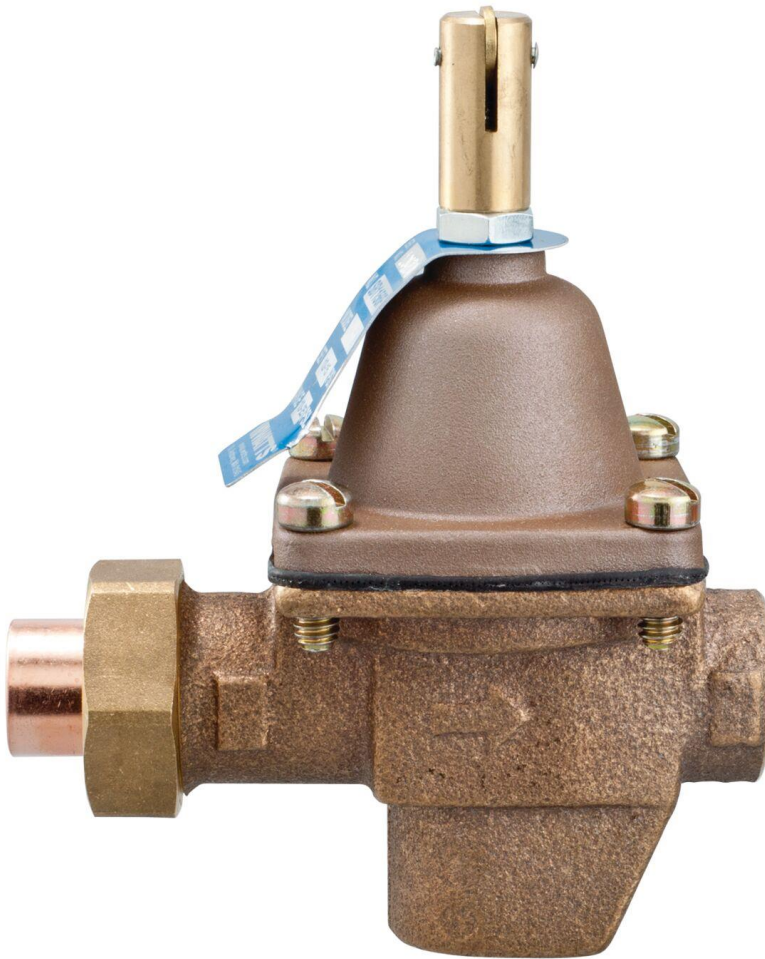

### Sustainability Mission Statement

#### **A Safer World is a More Sustainable World**

Watts was founded on a simple premise: the water we use every day should be delivered safely and reliably. We influenced the codes that shaped the way the world uses water. Our goal has always been to be good stewards of this critical resource while creating solutions that keep our customers safe where they live, work, and play. Watts believes a safer world is a more sustainable world.

#### EPD SCOPE

Cradle to Grave

#### Reference Standards

Core PCR	PCR for Building-Related Products and Services Part A v.3.2
Sub-Category PCR	UL Part B: Kitchen and Bath Fixture Fittings and Accessory Products v.1

#### PRODUCT SPECIFICATIONS

FUNCTIONAL UNIT: 1 PACKAGED PRODUCT

Model Size	0.5" SB1156F	Packaged Weight (kg)	0.839 kg
Product Service Life			20 years
Building Service Life			75 years

#### MANUFACTURING SPECIFICATIONS

Location	Franklin, NH
Energy Source	100% Offsite Wind Power RECs*

\*Model results shows Grid results with REC results shown in Further Information section at end

#### GREENHOUSE GAS EMISSION

Model Size	0.5" LFMMVM1-UT	IPCC AR5 GWP 100 A1-A3 (kg CO2 eq)	1.42e+1
------------	-----------------	------------------------------------	---------

Verified by:



# ENVIRONMENTAL PRODUCT DECLARATION

IN ACCORDANCE WITH ISO 14025 AND ISO 21930:2017

SmartEPD-2024-023-0167-01

## SB1156F - Hydronics



Date of Issue:  
Sep 30, 2024

Expiration:  
Sep 30, 2029

Last updated:  
Sep 30, 2024

---

General Information .....	3
Reference Standards .....	3
Verification Information .....	3
Limitations, Liability, and Ownership .....	4
Organization Information .....	4
Product Information .....	5
Plants .....	5
Product Specifications .....	5
Material Composition .....	5
Software and LCI Data Sources .....	6
EPD Data Specificity .....	6
Renewable Electricity .....	7
System Boundary .....	8
Product Flow Diagram .....	9
Life Cycle Module Descriptions .....	9
LCA Discussion .....	9
Results .....	11
Environmental Impact Assessment .....	11
Resource Use Indicators .....	12
Waste and output Flow Indicators .....	13
Carbon Emissions and Removals .....	13
Scenarios .....	14
Transport to the building/construction site (A4) .....	14
Installation in to the building/construction site (A5) .....	14
Reference Service Life (B1) .....	14
Repair (B3) .....	14



---

Replacement (B4) .....	15
End of Life (C1 - C4) .....	15
Interpretation .....	15
Further Information .....	16
References .....	16

## General Information

### Watts

815 Chestnut St, North Andover, MA 01845

1-978-689-6066

[watts.com](mailto:info@watts.com)

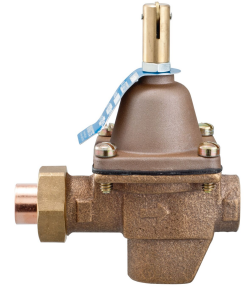

Product Name:	SB1156F - Hydronics
Functional Unit:	1 unit 1 packaged product
Declaration Number:	SmartEPD-2024-023-0167-01
Date of Issue:	September 30, 2024
Expiration:	September 30, 2029
Last updated:	September 30, 2024
EPD Scope:	Cradle to grave A1 - A3, A4, A5, B1 - B7, C1 - C4
Market(s) of Applicability:	North America, Europe

## Reference Standards

Standard(s):	ISO 14025 and ISO 21930:2017
Core PCR:	PCR for Building-Related Products and Services Part A v.3.2 Date of issue: December 12, 2018
Sub-category PCR:	UL Part B: Kitchen and Bath Fixture Fittings and Accessory Products v.1 Date of issue: October 08, 2020 Valid until: October 08, 2025
Sub-category PCR review panel:	Contact Smart EPD for more information.
General Program Instructions:	Smart EPD General Program Instructions v.1.0, November 2022

## Verification Information

LCA Author/Creator:	Olivia Tsamparlis    Watts Water   <a href="mailto:olivia.tsamparlis@wattswater.com">olivia.tsamparlis@wattswater.com</a>
	Vas Gnanadoss    Watts Water   <a href="mailto:vasanth.gnanadoss@wattswater.com">vasanth.gnanadoss@wattswater.com</a>
EPD Program Operator:	Smart EPD   <a href="mailto:info@smartepd.com">info@smartepd.com</a>   <a href="http://www.smartepd.com">www.smartepd.com</a>    585 Grove St., Ste. 145 PMB 966, Herndon, VA 20170, USA

**Verification:**

Independent critical review of the LCA and data, according to ISO 14044 and ISO 14071 :

External

 Gaspard Philis |  LCA.no |  gaspard@lca.no

Independent external verification of EPD, according to ISO 14025 and reference PCR(s) :

External

 Gaspard Philis |  LCA.no |  gaspard@lca.no

## Limitations, Liability, and Ownership

Environmental declarations from different programs (ISO 14025) may not be comparable. Comparison of the environmental performance of products using EPD information shall be based on the product's use and impacts at the building level, and therefore EPDs may not be used for comparability purposes when not considering the whole building life cycle. EPD comparability is only possible when all stages of a life cycle have been considered. However, variations and deviations are possible. Example of variations: Different LCA software and background LCI datasets may lead to differences results for upstream or downstream of the life cycle stages declared. The EPD owner has sole ownership, liability, and responsibility for the EPD.

## Organization Information

Watts Water Technologies, Inc. (Watts) is a global leader of quality water solutions for residential, industrial, municipal, and commercial settings. Our family of brands offers one of the most varied product lines in the world, with world-class, water-related solutions focused on Drainage, HVAC and Hot Water, Plumbing & Flow Control and Water Quality & Rainwater Harvesting.

Further information can be found at: <https://www.watts.com/>

## Product Description

Hydronic components are needed for creating safe and high performing hydronic and steam heating solutions. They are easy to Install, service, clean, and keep heating systems in compliance with necessary plumbing code and standards. This 1/2 inch high capacity feed water pressure regulator is for use in commercial and residential hydronic heating systems to fill the boiler and piping system with water, and to maintain water pressure in the system at all times. It also provides make-up water to the system in the event of system leaks. It consists of a bronze body with union solder inlet and NPT threaded outlet connections, a tight seating check valve, purge lever for manual purging, and a stainless steel strainer. It has high capacity performance and a simplified servicing design. It is suitable for use in the boiler feed lines of hydronic heating systems.

Further information can be found at: <https://www.watts.com/products/plumbing-flow-control-solutions/hydronic-steam-heating/boiler-feed-water-pressure-regulators/1156f/>

## Product Information

Functional Unit:	1 unit 1 packaged product
Mass:	0.83914588 kg
Reference Service Life:	20 Years
Product Specificity:	<input type="checkbox"/> Product Average
	<input checked="" type="checkbox"/> Product Specific

### Averaging:

Averaging was not conducted for this EPD.

## Plants

 Franklin Manufacturing Plant  
583 S Main St, Franklin, NH 03235, USA

## Product Specifications

Product SKU(s):	0386422
Product Classification Codes:	Masterformat - 15400
	UNSPSC - 401416
	EC3 - Plumbing -> PlumbingEquipment
	EC3 - Plumbing -> PlumbingFixtures -> OtherPlumbingFixtures

## Material Composition

Material/Component Category	Origin	% Mass
Body_Bronze	US	72
Spring Cage_Aluminium	CN	7
Union Nut_Brass	CN	3
Seal Cap_Brass	CN	2
Nameplate_Aluminium	US	2
Plate_Stainless Steel	US	1
Seat_Rubber	CN	1
Diaphragm_Buna	VN	1
Push Rod_Brass	US	1
Screw_Brass	US	1
Spring_Stainless Steel	US	1
Lever_Brass	US	1

Packaging Material	Origin	kg Mass
Paper	GLO	0.10433







Biogenic Carbon Content	kg C per unit
Biogenic carbon content in product	None
Biogenic carbon content in accompanying packaging	0.0516

Hazardous Materials
No regulated hazardous or dangerous substances are included in this product.

## EPD Data Specificity

- Primary Data Year: 2022
- Manufacturing Specificity:
- Industry Average
  - Manufacturer Average
  - Facility Specific

## Software and LCI Data Sources

LCA Software:	 SimaPro v. 9.5
LCI Foreground Database(s):	 Ecoinvent v. 3.9.1    RoW    Cut-Off by Classification
LCI Background Database(s):	 Ecoinvent v. 3.9.1    RoW    Cut-Off by Classification

## Renewable Electricity

Renewable electricity is used:	Yes
Electricity Source:	Offsite
Renewable type:	Wind
Percent of EPD Owner's product-related electricity covered:	100 %
Commitment pledged for entire EPD validity period:	Yes

## System Boundary

Production	A1	Raw material supply	✓
	A2	Transport	✓
	A3	Manufacturing	✓
Construction	A4	Transport to site	✓
	A5	Assembly / Install	✓
Use	B1	Use	✓
	B2	Maintenance	✓
	B3	Repair	✓
	B4	Replacement	✓
	B5	Refurbishment	✓
	B6	Operational Energy Use	✓
	B7	Operational Water Use	✓
End of Life	C1	Deconstruction	✓
	C2	Transport	✓
	C3	Waste Processing	✓
	C4	Disposal	✓
Benefits & Loads Beyond System Boundary	D	Recycling, Reuse Recovery Potential	ND

## Product Flow Diagram

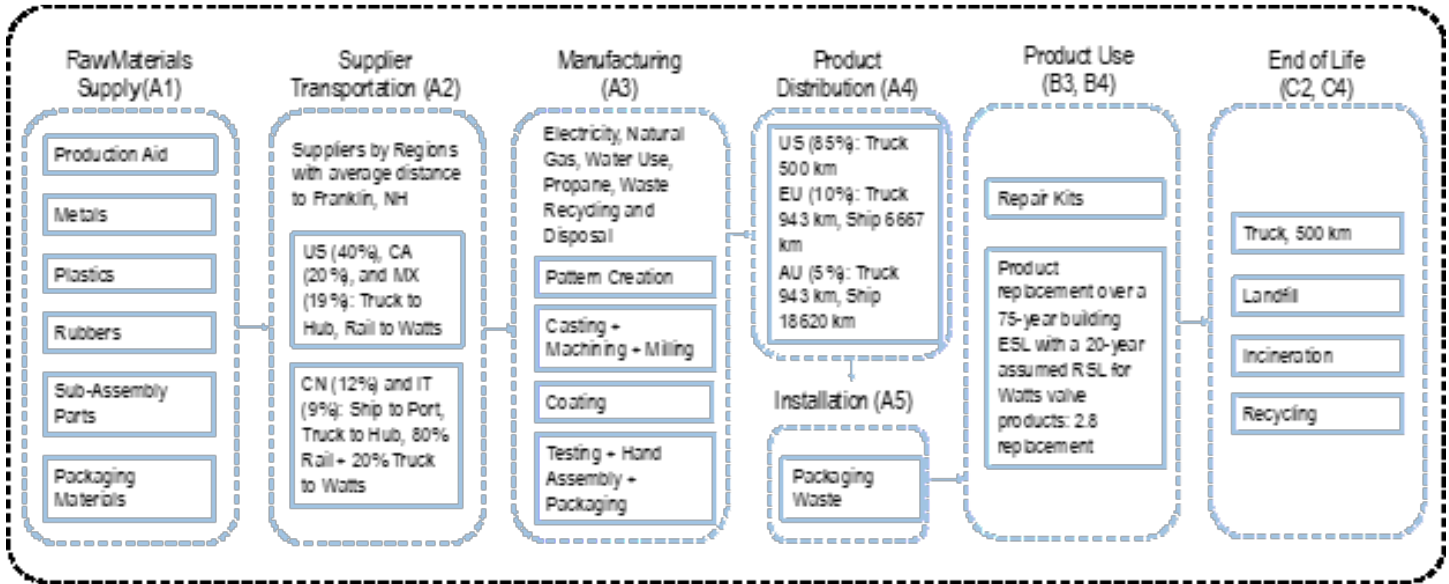

## Life Cycle Module Descriptions

The system boundary for this study is cradle-to-grave with modules A1-C4, covering supplied raw materials (A1), transport from suppliers to Watts (A2), production of manufactured products (A3), transport from Watts to customers (A4), product's installation (A5), product repair (B3), replacement (B4), transport to end-of-life facilities (C2), and disposal of the product (C4).

Each module includes provision of all relevant materials, products, and energy. Potential impacts and aspects related to wastage (i.e. production, transport and waste processing and end-of-life stage of lost waste products and materials) are considered in the module in which the wastage occurs.

No impacts from the product's use (B1, B2, B5-B7) or from demolition (C1) or waste processing (C3) are included. Waste processing is not included because the product is sent directly to disposal (C4). The installation module A5 contains only the packaging waste, other impacts in this module are declared as having zero impact as the process is manual using hand tools that don't consume energy. The use stage modules B1, B2, B5 to B7 are declared as having zero impacts as there are no direct energy or water use during consume use, nor is any direct emissions from the valve products once they are installed. The other use stage modules account for B3, materials needed for repair (i.e., repair kits description) and B4, replacing the valve to match building service life.

## LCA Discussion

### Allocation Procedure

While conducting an LCA, if the life cycles of more than one product are connected, allocation of the process inputs should be avoided by using the system boundary expansion approach. In accordance with the ISO 14040 series and PCR, mass should be used as the primary basis for co-product allocation. The allocations of relevance for calculation (appropriation of impacts across various products) shall be indicated, at least:

- Allocation in the use of recycled and/or secondary raw materials.
- Allocation of energy, ancillary and operating materials used for individual products in a factory.

No multi-output allocation was necessary in the foreground of the study. Allocation of secondary data taken from ecoinvent v3.9.1 cut-off by classification has allocation applied to it.

Given that raw materials are key contributors to environmental performance, mass-based allocation of plant overhead utility consumption, resource use and waste generation was applied for Franklin facility, where all products in this study are manufactured. Operational manufacturing energy and water inputs and waste stream are allocated to total pound of product output per product category based on earned hours, then to 1 pound of product. No allocation is required for products at end-of-life: product scrap and packaging waste at the job site is assumed to be inert in landfills, so no landfill gas is produced from product waste.

## Cut-off Procedure

For the processes within the system boundary all energy and material flows have been included in the model. PCR allows for any mass flow to be omitted if it is less than 1%, with cumulative flows not exceeding 5%. In situations where gathering accurate weight data for smaller components acquired from suppliers, such as o-rings or tiny metal inserts, presents a challenge, the total weight of materials listed in the Bill of Materials (BOM) might not precisely align with the product's total weight as recorded in the system. To accommodate this discrepancy, a 5% cut-off criterion (note 1) has been implemented in the A1, Raw Material Calculation process. This approach helps ensure more accurate and realistic accounting of materials, despite the challenges in obtaining exact weights of smaller parts.

For other life cycle modules, this study includes 100% of the material flows; no known flows are excluded. Results from manufacturing are limited to the primary data obtained from product throughput and annual reports. The amount spent on production aides was minimal, so they were considered negligible and not included. All upstream and downstream activities are included using a combination of primary and secondary data. While the majority of inventory data are sourced from primary resources, representative proxies are used to close gaps in the absence of primary data.

This study uses the cut-off approach method for recycling. According to this approach, the first life of a material bears the environmental burdens of its production (e.g., raw material extraction and processing) and the second life (e.g., scrap input) bears the burdens of refurbishment (e.g., collection and refining of scrap). The burdens from waste treatment are taken by the life after which they occur.

Note 1: In the study, we have accounted for 100% of the materials by mass as detailed in the product's bill of materials, which includes not only the core components but also production aids and packaging. However, when aggregating the actual weights for each specific part, there may be a slight variance of up to +/- 5% between the sum of the weights of all components and the total product weight recorded in Watt's internal system. It is important to note that the internal system's figures are based on approximate product specifications and serve as a reference. Therefore, any perceived discrepancies or a 5% cut-off are due to these approximations and do not reflect omissions in our materials accounting.

## Data Quality Discussion

Life cycle inventory data used in this study are evaluated based on three categories: precision and completeness, consistency and reproducibility, and representativeness.

Precision and completeness: Foreground data are sourced from primary information provided by the client and has been reviewed internally to ensure precision and completeness. In order to balance out seasonal variations, operations data over a 12-month period is used to represent production activities. In addition, key model input such as mass balance, energy balance and emission inventory are reviewed by TrueNorth Collective team.

Ecoinvent v3.9.1 cut-off by classification is used as the main database for background data. This version is published in 2023. Ecoinvent is widely used in research and industry to support life cycle assessment practices. Each version of this database goes through thorough review process and documentation of precision and completeness is available by the provider.

Consistency and reproducibility: To ensure consistency, primary data were collected at the same level of granularity. All input and output information, modelling assumptions and dataset choices are provided in this report for the purpose of reproducibility.

Representativeness: Refer to the sections above for details about representativeness.

## Results

### Environmental Impact Assessment Results

IPCC AR5 GWP 100, TRACI 2.1

per 1 unit.

LCIA results are relative expressions and do not predict impacts on category endpoints, the exceeding of thresholds, safety margins or risks.

Impact Category	Method	Unit	A1A2A3	A4	A5	B1	B2	B3	B4	B5	B6	B7	C1	C2	C3	C4
GWP-total	IPCC AR5 GWP 100	kg CO2 eq	1.42e+1	1.30e-1	4.28e-2	0	0	2.95e-1	4.02e+1	0	0	0	0	2.28e-2	0	1.67e-2
GWP-total	TRACI 2.1	kg CO2 eq	1.39e+1	1.28e-1	3.57e-2	0	0	2.65e-1	3.96e+1	0	0	0	0	2.25e-2	0	1.64e-2
ODP	TRACI 2.1	kg CFC 11 eq	2.59e-7	2.15e-9	7.30e-11	0	0	6.52e-9	7.33e-7	0	0	0	0	3.77e-10	0	2.77e-10
AP	TRACI 2.1	kg SO2 eq	3.01e-1	6.97e-4	2.63e-5	0	0	6.79e-4	8.44e-1	0	0	0	0	1.22e-4	0	1.17e-4
EP-fw	TRACI 2.1	kg N eq	2.30e-1	1.33e-4	1.93e-4	0	0	1.32e-3	6.46e-1	0	0	0	0	2.32e-5	0	3.88e-5
POCP	TRACI 2.1	kg O3 eq	1.46e+0	1.95e-2	6.04e-4	0	0	1.00e-2	4.17e+0	0	0	0	0	3.42e-3	0	1.84e-3

**Abbreviations:**

GWP = Global Warming Potential, 100 years (may also be denoted as GWP-total, GWP-fossil (fossil fuels), GWP-biogenic (biogenic sources), GWP-luluc (land use and land use change)), ODP = Ozone Depletion Potential, AP = Acidification Potential, EP = Eutrophication Potential, SFP = Smog Formation Potential, POCP = Photochemical oxidant creation potential, ADP-Fossil = Abiotic depletion potential for fossil resources, ADP-Minerals&Metals = Abiotic depletion potential for non-fossil resources, WDP = Water deprivation potential, PM = Particular Matter Emissions, IRP = Ionizing radiation, human health, ETP-fw = Eco-toxicity (freshwater), HTP-c = Human toxicity (cancer), HTP-nc = Human toxicity (non-cancer), SQP = Soil quality index.

Comparisons cannot be made between product-specific or industry average EPDs at the design stage of a project, before a building has been specified. Comparisons may be made between product-specific or industry average EPDs at the time of product purchase when product performance and specifications have been established and serve as a functional unit for comparison. Environmental impact results shall be converted to a functional unit basis before any comparison is attempted. Any comparison of EPDs shall be subject to the requirements of ISO 21930 or EN 15804. EPDs are not comparative assertions and are either not comparable or have limited comparability when they have different system boundaries. EPDs are not comparative assertions and are either not comparable or have limited comparability when they have different system boundaries, are based on different product category rules or are missing relevant environmental impacts. Such comparison can be inaccurate, and could lead to erroneous selection of materials or products which are higher-impact, at least in some impact categories.

**Resource Use Indicators**  
per 1 unit.

Indicator	Unit	A1A2A3	A4	A5	B1	B2	B3	B4	B5	B6	B7	C1	C2	C3	C4
PERE	MJ	ND	ND	ND	ND	ND	ND	ND	ND	ND	ND	ND	ND	ND	ND
PERM	MJ	ND	ND	ND	ND	ND	ND	ND	ND	ND	ND	ND	ND	ND	ND
PERT	MJ	ND	ND	ND	ND	ND	ND	ND	ND	ND	ND	ND	ND	ND	ND
PENRE	MJ	ND	ND	ND	ND	ND	ND	ND	ND	ND	ND	ND	ND	ND	ND
PENRM	MJ	ND	ND	ND	ND	ND	ND	ND	ND	ND	ND	ND	ND	ND	ND
PENRT	MJ	ND	ND	ND	ND	ND	ND	ND	ND	ND	ND	ND	ND	ND	ND
RPRE	MJ	3.20e+1	2.32e-2	1.19e-3	0	0	1.36e+0	8.98e+1	0	0	0	0	4.07e-3	0	1.43e-2
RPRM	MJ	0	0	0	0	0	0	0	0	0	0	0	0	0	0
RPRT	MJ	3.20e+1	2.32e-2	1.19e-3	0	0	1.36e+0	8.98e+1	0	0	0	0	4.07e-3	0	1.43e-2
NRPRE	MJ	2.25e+2	1.95e+0	6.03e-2	0	0	2.46e+0	6.38e+2	0	0	0	0	3.43e-1	0	2.78e-1
NRPRM	MJ	1.08e+0	0	0	0	0	0	3.01e+0	0	0	0	0	0	0	0
NRPRT	MJ	2.26e+2	1.95e+0	6.03e-2	0	0	2.46e+0	6.41e+2	0	0	0	0	3.43e-1	0	2.78e-1
ADP-fossil	MJ	1.91e+1	2.58e-1	7.64e-3	0	0	2.67e-1	5.44e+1	0	0	0	0	4.52e-2	0	2.82e-2
SM	kg	0	0	0	0	0	0	0	0	0	0	0	0	0	0
RSF	MJ	0	0	0	0	0	0	0	0	0	0	0	0	0	0
NRSF	MJ	0	0	0	0	0	0	0	0	0	0	0	0	0	0
FW	m3	2.72e-4	0	0	0	0	0	7.61e-4	0	0	0	0	0	0	0

Abbreviations:  
RPRE or PERE = Renewable primary resources used as energy carrier (fuel), RPRM or PERM = Renewable primary resources with energy content used as material, RPRT or PERT = Total use of renewable primary resources with energy content, NRPRE or PENRE = Non-renewable primary resources used as an energy carrier (fuel), NRPRM or PENRM = Non-renewable primary resources with energy content used as material, NRPRT or PENRT = Total non-renewable primary resources with energy content, SM: Secondary materials, RSF = Renewable secondary fuels, NRSF = Non-renewable secondary fuels, RE = Recovered energy, ADPF = Abiotic depletion potential, FW = Use of net freshwater resources, VOCs = Volatile Organic Compounds.

**Waste and Output Flow Indicators**  
per 1 unit.

Indicator	Unit	A1A2A3	A4	A5	B1	B2	B3	B4	B5	B6	B7	C1	C2	C3	C4
HWD	kg	2.43e-1	0	0	0	0	0	6.81e-1	0	0	0	0	0	0	0
NHWD	kg	2.32e-2	0	0	0	0	0	6.49e-2	0	0	0	0	0	0	0
RWD	kg	ND	ND	ND	ND	ND	ND	ND	ND	ND	ND	ND	ND	ND	ND
HLRW	kg	0	0	0	0	0	0	0	0	0	0	0	0	0	0
ILLRW	kg	0	0	0	0	0	0	0	0	0	0	0	0	0	0
CRU	kg	0	0	0	0	0	0	0	0	0	0	0	0	0	0
MFR	kg	2.44e-1	0	0	0	0	0	6.84e-1	0	0	0	0	0	0	0
MER	kg	0	0	0	0	0	0	0	0	0	0	0	0	0	0
MNER	kg	ND	ND	ND	ND	ND	ND	ND	ND	ND	ND	ND	ND	ND	ND
EEE	MJ	0	0	0	0	0	0	0	0	0	0	0	0	0	0
EET	MJ	ND	ND	ND	ND	ND	ND	ND	ND	ND	ND	ND	ND	ND	ND

Abbreviations:  
HWD = Hazardous waste disposed, NHWD = Non-hazardous waste disposed, RWD = Radioactive waste disposed, HLRW = High-level radioactive waste, ILLRW = Intermediate- and low-level radioactive waste, CRU = Components for re-use, MFR or MR = Materials for recycling, MER = Materials for energy recovery, MNER = Materials for incineration, no energy recovery, EE or EEE = Recovered energy exported from the product system, EET = Exported thermal energy.

**Carbon Emissions and Removals**  
per 1 unit.

Indicator	Unit	A1A2A3	A4	A5	B1	B2	B3	B4	B5	B6	B7	C1	C2	C3	C4
BCRP	kg CO2	0	0	0	0	0	0	0	0	0	0	0	0	0	0
BCEP	kg CO2	0	0	0	0	0	0	0	0	0	0	0	0	0	0
BCRK	kg CO2	-1.89e-1	0	0	0	0	-1.74e-1	-5.30e-1	0	0	0	0	0	0	0
BCEK	kg CO2	0	0	2.13e-1	0	0	4.35e-2	5.97e-1	0	0	0	0	0	0	0
BCEW	kg CO2	0	0	0	0	0	0	0	0	0	0	0	0	0	0
CCE	kg CO2	0	0	0	0	0	0	0	0	0	0	0	0	0	0
CCR	kg CO2	0	0	0	0	0	0	0	0	0	0	0	0	0	0
CWNR	kg CO2	0	0	0	0	0	0	0	0	0	0	0	0	0	0

Abbreviations:  
BCRP = Biogenic Carbon Removal from Product, BCEP = Biogenic Carbon Emission from Product, BCRK = Biogenic Carbon Removal from Packaging, BCEK = Biogenic Carbon Emission from Packaging, BCEW = Biogenic Carbon Emission from Combustion of Waste from Renewable Sources Used in Production Processes, CCE = Calcination Carbon Emissions, CCR = Carbonation Carbon Removals, CWNR = Carbon Emissions from Combustion of Waste from Non-Renewable Sources used in Production Processes, GWP-luc = Carbon Emissions from Land-use Change.

## Scenarios

### Transport to the building/construction site (A4)

A4 Module

Fuel Type:	Diesel
Liters of Fuel:	27.6 l/100km
Vehicle Type:	16-32 metric ton, EURO3 Truck
Transport Distance:	2700 km
Capacity Utilization:	37 %
Packaging Mass:	0.1043 kg
Weight of products transported:	0.839 kg
Capacity utilization volume factor:	<1
Assumptions for scenario development:	<p>Products are shipped out from Watts facility in Franklin, NH, on pallets to customers directly. 85% of customers are based in US, 10% in Europe, mostly France and 5% in Australia. The study uses a conservative assumption that packaged products are shipped via a 16-32 metric ton, EURO3 truck using diesel fuel for US, EU, and AU and a freight container ship using heavy fuel oil for EU and AU. Above information represents North American transport as this covers 85% of transportation. The total transportation impacts of the A4 phase were calculated based on a weighted average of:</p> <ul style="list-style-type: none"> <li>•Franklin, NH to US Customer: 2700 km by truck (85%)</li> <li>•Franklin, NH to EU Customer: 943 km by truck and 6667 km by ship (10%)</li> <li>•Franklin, NH to AU Customer: 943 km by truck and 18520 km by ship (5%)</li> </ul>
Truck Distance (weighted average for US, EU and AU customer):	2436.45 km
Freight Container Ship Distance (weighted average for EU and AU customer):	1592.7 km

### Installation in to the building/construction site (A5)

A5 Module

Mass of Packaging Waste Specified by Type:	0.10433 kg
Biogenic Carbon Contained in Packaging:	0.189 kg
Assumptions for scenario development:	<p>The installation process is manual using hand tools that don't consume energy. Therefore, only product packaging waste is included in this module. It is assumed all packaging wastes are transported to a waste treatment facility with an average of 100 km by truck. Other impacts in this module are declared as having zero impact. The paper and paperboard packaging EOL assumptions are based on the EPA recommendation of:</p> <ul style="list-style-type: none"> <li>-Recycled Percentage: 68.21%</li> <li>-Incineration Percentage: 6.23%</li> <li>-Landfill Percentage: 25.55%</li> </ul>

### Reference Service Life

B1 Module

RSL:	20 Years
------	----------

## Repair (B3)

B3 Module

<b>Repair Cycle:</b>	1 Cycles/RSL
<b>Ancillary Materials Specified by Type:</b>	0.0106 kg
<b>Waste Materials From Repair:</b>	0.0106 kg
<b>Repair Process Information:</b>	Repair processes are done manually. Parts are replaced with identical parts from a standard repair kit specific to the product.
<b>Further assumptions for scenario development:</b>	Total weight of repair kits is 0.0106 kg which includes the Orings, diaphragm, and disk.

## Replacement (B4)

B4 Module

<b>Reference Service Life:</b>	20 Years
<b>Replacement Cycle:</b>	2.8 (ESL/RSL)-1
<b>Further assumptions for scenario development:</b>	Product replacement over a 75-year building ESL with a 20-year assumed RSL for Watts valve products, is calculated as a total of 3.8 [ $75 / 20 = 3.75$ , rounded-up to the nearest tenth] of valves needed over the building's lifetime. Total replacement is calculated as 2.8 [ $75 / 20 - 1 = 2.75$ , rounded-up to the nearest tenth] of valves. B4 includes these life cycle stages (A1-A5, C2 and C4)

## End of Life

C1 - C4 Modules

### Collection Process

<b>Collected Separately:</b>	0.735 kg
------------------------------	----------

### Recovery

<b>Landfill:</b>	0.735 kg
------------------	----------

### Assumptions for scenario development:

A 16-32 metric ton, EURO3 truck is used for EOL transportation with an average distance of 100 km by truck (C2).  
Due to mixed materials product is assumed to be landfilled at 100% rate (C4).

## Interpretation

The analysis of Watts valve products provides useful insights regarding the cradle-to-grave environmental impacts. The LCA results also identify where substantial impacts are occurring to allow further process and materials improvements to be implemented by Watts. The cradle-to-grave impacts for all products are dominated by the B4 replacement phase as ~2.8 declared units are needed to reach the 75 year building lifespan per the PCR requirement. This stage typically accounts for ~70% of the impacts throughout the products' lifecycle. After this the second largest contributor is the A1 Raw Materials Extraction and Processing stage. This stage accounts for ~10-20% of the lifecycle impacts. The A3 Manufacturing stage accounts for 5-10% of the impacts, with the other stages accounting for <1%.

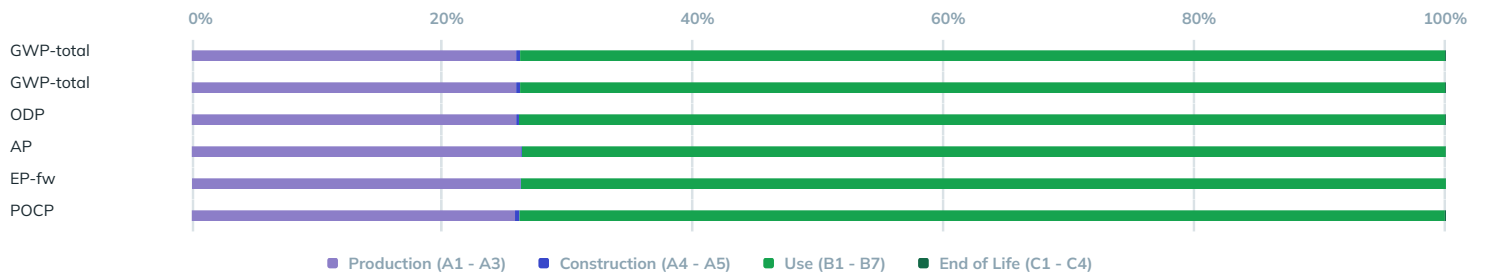

### Environmental Activities and Certifications

Certification
ISO 9001
ISO 14001

### Further Information

#### Impact Assessment Percent Reduction with REC

LCIA Method	Impact Category	Unit	A1A2A3
IPCC AR5 GWP 100	IPCC AR5 GWP 100	kg CO2	1.71E+01
TRACI 2.1	GWP 100	kg CO2 eq.	1.70E+01
TRACI 2.1	ODP	kg CFC-11 eq.	2.30E-07
TRACI 2.1	AP	kg SO2 eq.	5.83E-01
TRACI 2.1	EP	kg N eq.	1.81E-01
TRACI 2.1	POCP	kg C2H4 eq.	2.63E-02

#### Impact Assessment Percent Reduction with REC

The percent reduction of cradle-to-gate impacts with Renewable Energy Credits (RECs) is calculated as:

- IPCC AR5 GWP 100, GWP-total = 7.4% reduction
- TRACI 2.1, GWP-total = 7.4% reduction
- TRACI 2.1, ODP = 1.7% reduction
- TRACI 2.1, AP = 0.13% reduction
- TRACI 2.1, EP-fw = 0.14% reduction
- TRACI 2.1, POCP = 0.35% reduction

## References

Product Page: <https://www.watts.com/products/plumbing-flow-control-solutions/relief-valves/asme-safety-valves/335/m335m2-030-34>  
Product Specification: <https://www.watts.com/dfsmedia/0533dbba17714b1ab581ab07a4cbb521/24691-source/es-335-pdf>  
BOM information: Internal ERP System

### Other References:

- ACLCA. (2019). ACLCA Guidance to Calculating Non-LCIA Inventory Metrics in Accordance with ISO 21930:2017. ACLCA.
- Bare, J., Gloria, T., & Norris, G. (2006). Development of the Method and U.S. Normalization Database for Life Cycle Impact Assessment and Sustainability Metrics. Environmental Science & Technology .
- Bare, J., Norris, G., Pennington, D., & McKone, T. (2003). TRACI: The Tool for the Reduction and Assessment of Chemical and Other Environmental Impacts. Journal of Industrial Ecology .
- Boulay A.M., B. J. (2018). The WULCA consensus characterization model for 108 water scarcity footprints: Assessing impacts of water consumption based on available water remaining (AWARE) . The International Journal of Life Cycle Assessment .
- Center of Environmental Science, L. U. (2016). CML-IA Characterisation Factors.
- Frischknecht, R., Jungbluth, N., Althaus, H., Doka, G., Dones, R., Hirschler, R., . . . Nemecek, T. (2007). Implementation of Life Cycle Impact Assessment Methods: Data v2.0. Dübendorf, Switzerland: ecoinvent report No. 3, Swiss centre for Life Cycle Inventories.
- IPCC, I. P. (2013). IPCC Fifth Assessment report. The Physical Science Basis. Retrieved from <http://www.ipcc.ch/report/ar5/wg1/>.
- ISO 14025. (2006). ISO 14025:2006: Environmental labels and declarations — Type III environmental declarations — Principles and procedures. International Organization for Standardization.
- ISO 14040. (2006). ISO 14040:2006/Amd 1:2020 -- Environmental management -- Life cycle assessment -- Principles and framework. International Organization for Standardization.
- ISO. (2006). ISO 14040:2006 Environmental management - Life cycle assessment - Principles and framework. International Organization for Standardization (ISO).
- ISO. (2006). ISO 14044:2006 Environmental management - Life cycle assessment - Requirements and guidelines. International organization for Standardization (ISO).
- ISO 21930. (2017). Sustainability in buildings and civil engineering works — Core rules for environmental product declarations of construction products and services.
- UL. (2018). Product Category Rules for Building Related Products and Services, Part A: Life Cycle Assessment Calculation Rules and Report Requirements UL 10010, v3.2. UL.
- UL. (2020). Product Category Rules (PCR) Guidance for Building-Related Products and Services – Part B: Kitchen and Bath Fixture Fittings and Accessory Products EPD Requirements, UL Environment, (UL 10010-34, Edition 2).
- UL. (2024). Product Category Rules for UL Part B: Kitchen and Bath Fixture Fittings and Accessory Products EPD Requirements, UL Standard 10010-28, Version 1.0.
- Weidema B P, B. C. (2013). Overview and methodology. Data quality guideline for the ecoinvent database version 3. St. Gallen: The ecoinvent Centre.

## Engineering Specification

Job Name \_\_\_\_\_

Contractor \_\_\_\_\_

Job Location \_\_\_\_\_

Approval \_\_\_\_\_

Engineer \_\_\_\_\_

Contractor's P.O. No. \_\_\_\_\_

Approval \_\_\_\_\_

Representative \_\_\_\_\_

# Series 1156F

## Feed Water Pressure Regulators

Size: 1/2"

Series 1156F feed water pressure regulators are designed to fill the boiler and system piping with water and to maintain water pressure in the system at all times. These valves also provide make up water to the system in the event of system leaks. Series 1156F features a high capacity performance as well as unique simplified servicing accessibility for complete unitized maintenance.

### Features

- Choice of inlet connections (threaded, union solder or union threaded)
- Tight seating check valve
- Purge lever for manual purging
- High capacity
- Stainless steel strainer to protect the valve disc from fouling

### Specifications

A feed water pressure regulator shall be installed on the boiler or where indicated on the plans to fill boiler piping with water and to provide make up water in the event of system leaks. The regulator shall have high capacity performance and a simplified servicing design. The feed water pressure regulator shall be a Watts Series 1156F.

### Models

<b>1156F</b>	Threaded inlet connection
<b>S1156F</b>	Union solder inlet connection
<b>T1156F</b>	Union threaded inlet connection
<b>B1156F</b>	Bronze valve body with threaded inlet connection
<b>TB1156F</b>	Bronze valve body with union threaded inlet connection
<b>SB1156F</b>	Bronze valve body with union solder inlet connection

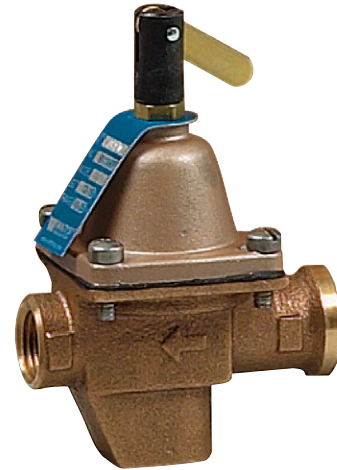

B1156F

#### NOTICE

The information contained herein is not intended to replace the full product installation and safety information available or the experience of a trained product installer. You are required to thoroughly read all installation instructions and product safety information before beginning the installation of this product.

#### NOTICE

Inquire with governing authorities for local installation requirements

Watts product specifications in U.S. customary units and metric are approximate and are provided for reference only. For precise measurements, please contact Watts Technical Service. Watts reserves the right to change or modify product design, construction, specifications, or materials without prior notice and without incurring any obligation to make such changes and modifications on Watts products previously or subsequently sold.



## Pressure – Temperature

Maximum Temperature: 212°F (100°C)

Maximum Working Pressure: 100psi (6.9 bar)

Adjustment Range: 10 – 25psi (68.7 – 172.4 kPa) set at 15psi (103.4 kPa)

## Dimensions – Weights

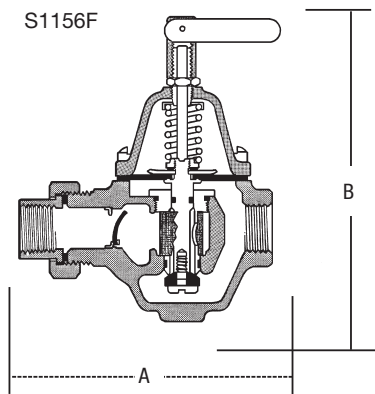

MODEL	SIZE		DIMENSIONS						WEIGHT	
	<i>in.</i>	<i>in.</i>	A <i>mm</i>	<i>in.</i>	B <i>mm</i>	<i>in.</i>	C <i>mm</i>	<i>lbs.</i>	<i>kgs.</i>	
1156F	½	¾	89	5⅜	137	–	–	2.1	.95	
T1156F	½	4¼	108	5⅜	137	–	–	2.2	1	
S1156F	½	4⅝	105	5⅜	137	–	–	2.3	1	
*B1156F	½	¾	89	5⅜	137	–	–	2.1	1	
*SB1156F	½	4⅜	111	5⅜	137	–	–	2.2	1	
*TB1156F	½	4⅝	105	5⅜	137	–	–	2.3	1	

\* Bronze body

